

QUALSTAR FIBRE CHANNEL OPTION

HIGH SPEED DATA TRANSFER
FOR TLS-SERIES SANSmart™
AUTOMATED TAPE LIBRARIES



The Fibre Channel Option (FCO) connects TLS-Series SANSmart™ automated tape libraries to Storage Area Networks (SAN). SAN technology provides high-speed data transfer, unencumbered by LAN user traffic, for backup, data migration and other throughput-intensive applications.

INDUSTRY LEADING PERFORMANCE

The FCO incorporates the latest semiconductor technology to provide sustained data transfer rates approaching 100 MB/second and delivering over 8,500 IOPS. Each FCO contains three Ultra2 SCSI busses to insure that the tape drives within the library are able to achieve and sustain their maximum aggregate throughput. Dual FCOs can be specified on eight- and twelve-drive libraries, providing two independent Fibre Channel connections to eliminate data bottlenecks.

EASY IMPLEMENTATION

The FCO uses industry standard Gigabit Interface Converters (GBIC) to support both copper and fibre optic connectivity to deliver sustained performance over distances up to 10 kilometers. The FCO supports Fibre Channel Arbitrated Loop (FC-AL) topology and Fibre Channel Switched

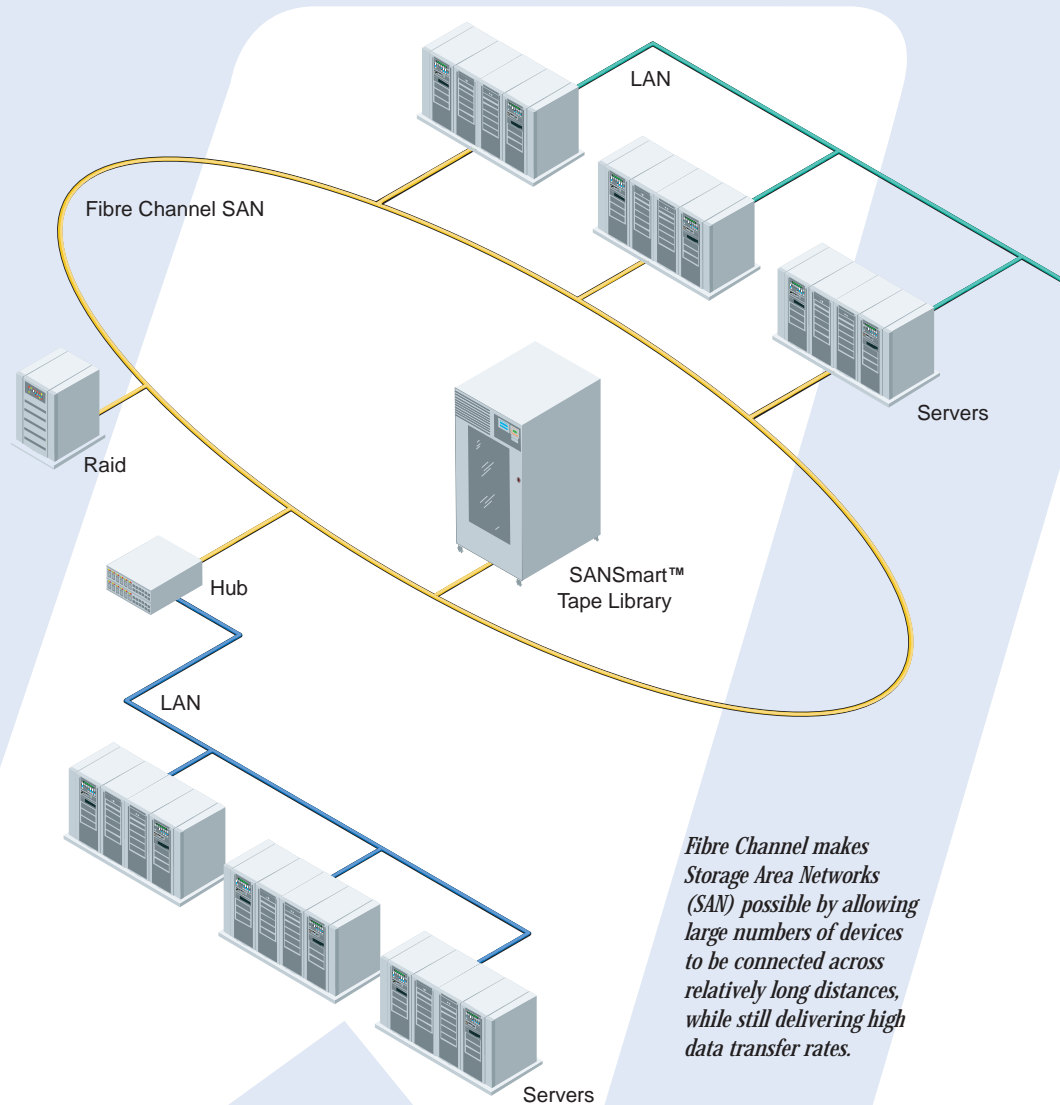

Fibre Channel makes Storage Area Networks (SAN) possible by allowing large numbers of devices to be connected across relatively long distances, while still delivering high data transfer rates.

Fabric (FC-SW) topologies to integrate into most SAN architectures. Popular host bus adapters, hubs and switches are supported to provide easy connectivity in most installations.

FAST INSTALLATION

The FCO is fully integrated with the TLS menu control system, providing

complete configuration and management from the library front panel. No additional installation software is required.

QUALSTAR: SIMPLY RELIABLE

Qualstar's "Simply Reliable" Tape Libraries are the preferred choice of IT professionals worldwide.

QUALSTAR FIBRE CHANNEL OPTION

HIGH SPEED DATA TRANSFER
FOR TLS-SERIES SANS*mart*[™]
AUTOMATED TAPE LIBRARIES



TECHNICAL SPECIFICATIONS

- One Fibre Channel host port
- Over 90 MB/second
- Over 8,500 IOPS
- FC-AL and FC-SW topologies
- PLDA compliant
- Class 3 service
- SCSI-FCP protocol
- 3 Ultra2 LVD SCSI channels

OPTIONS

GBIC	Transmission Distance	Part Number
Multimode Optical	500 Meters	648-0105-3
Single Mode Optical	10 Kilometers	648-0105-1
Copper, DB-9 (Active)	25 Meters	648-0103-8
Copper, HSSDC (Active)	25 Meters	648-0104-6

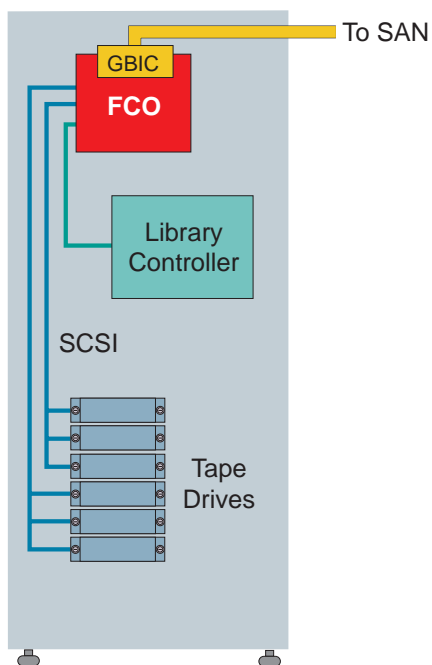

SINGLE FIBRE CHANNEL OPTION

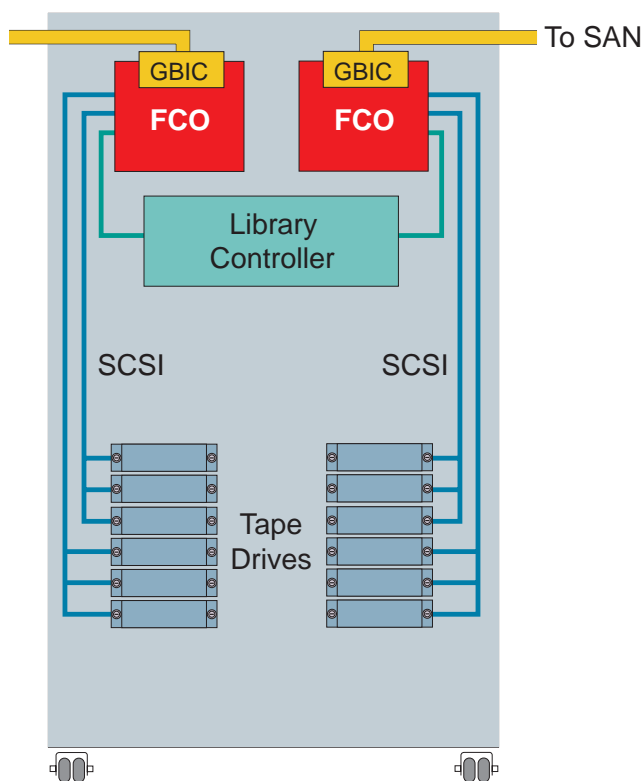

DUAL FIBRE CHANNEL OPTION

QUALSTAR CORPORATION
3990-B Heritage Oak Court
Simi Valley, CA 93063

Nasdaq National Market: QBAK

Fax: 805-583-7749

Tel: 805-583-7744

800-468-0680

E-mail: sales@qualstar.com

Website: www.qualstar.com

Qualstar Corporation does not warrant the MEBF to be representative of any particular unit installed for customer use. Failure rates are derived from a large database of test samples. The individual failure rate will vary from unit to unit.

All information and specifications are based on our knowledge of the products at the time of printing. We believe this information to be correct, however, Qualstar reserves the right to change specifications without notice.

Qualstar and the Qualstar logo are registered trademarks of Qualstar Corporation. All other trademarks are the property of their respective owners.

Copyright © 2001 Qualstar Corporation. All rights reserved. Printed in USA. DS 264 3/01